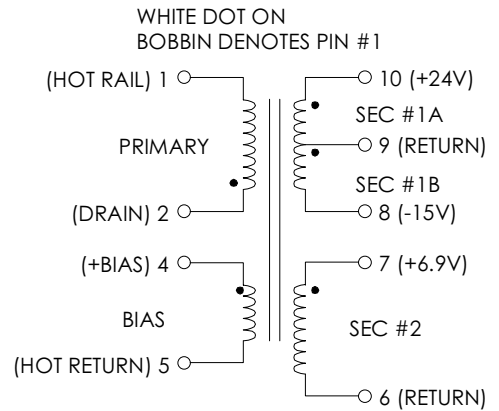

**TABLE 1: ELECTRICAL SPECIFICATIONS AT 25 °C**  
 SWITCHING TRANSFORMER DESIGNED FOR USE WITH POWER INTEGRATIONS  
 TOP224. REFER TO APPLICATION CIRCUIT OF FIGURE 3.

PARAMETER	SPEC LIMITS			UNITS
	MIN.	TYP.	MAX.	
PRIMARY INDUCTANCE (3-1) VOLTAGE = 0.250Vrms FREQUENCY = 100 KHZ	810	900	990	μHY
TURN RATIO'S: SEC #1A (10-9) : PRIMARY (2-1) SEC #1B (10-9) : PRIMARY (2-1) SEC #2 (7-6) : PRIMARY (2-1) BIAS (4-5) : PRIMARY (2-1)	-----	1: 4.30 1: 7.17 1:14.33 1: 8.60	-----	± 4% ± 4% ± 4% ± 4%
PRI LEAKAGE IND. (SEC SHORTED) VOLTAGE = 0.250Vrms FREQUENCY = 100 KHZ	-----	-----	28.0	μHY
HIPOT: PRIMARY TO SECONDARY BIAS TO SECONDARY	3000 3000	----- -----	----- -----	Vrms Vrms
APP CIRCUIT PARAMETERS: (1) AC LINE VOLTAGE 47/400 Hz SEC #1A OUTPUT VOLTAGE SEC #1A OUTPUT CURRENT SEC #1A OUTPUT VOLTAGE SEC #1A OUTPUT CURRENT SEC #2 REGULATED OUTPUT SEC #2 OUTPUT CURRENT	85 ----- 25.0 ----- 25.0 ----- 25.0	----- 24.0 ----- 15.0 ----- 6.9 -----	265 ----- 600 ----- 200 ----- 300	Vac ±Vdc ±mA ±Vdc ±mA Vdc ±mA

**FIGURE 1: SCHEMATIC DIAGRAM**



**NOTE1:**  
**REINFORCED INSULATION SYSTEM, UL1950, IEC950, CSA-950:**  
 A) ALL MATERIALS MEET "UL", "CSA" & "IEC" REQUIREMENTS  
 B) MARGIN WOUND FOR >2.5mm CREEPAGE  
 C) DESIGNED FOR >5.0mm CLEARANCE REQUIREMENTS.  
 D) VARNISH FINISHED ASSEMBLY.  
 E) UL CLASS (B) 130 INSULATION SYSTEM PM130-H1A  
 (UL FILE #E177139) OR ANY UL AUTHORIZED  
 CLASS (B) INSULATION SYSTEM.

(1) REFER TO APPLICATION CIRCUIT OF FIGURE 3.

**FIGURE 2: PHYSICAL DIMENSIONS mm (INCHES)**

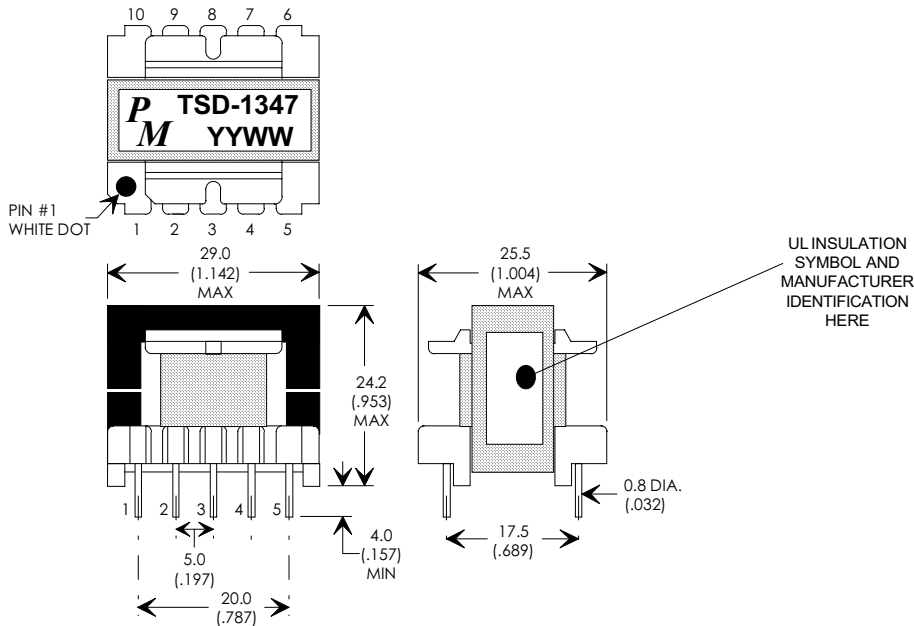

REV.	DESCRIPTION OF CHANGES	BY
12/01/98	ORIGINAL RELEASE	TO
09/17/99	UPDATE TO UL CLASS (B) 130 INSULATION SYSTEM	MD

EE, EI28/11, 10-PIN VERTICAL BOBBIN



UNLESS OTHERWISE SPECIFIED  
 DIMENSIONS ARE IN MM  
 DIMENSIONAL TOLERANCES ARE:  
 DECIMALS ANGLES  
 .X ± .25 ±0° 30'  
 .XX ± .15  
 DO NOT SCALE DRAWING

**FLYBACK TRANSFORMER CONTROL DRAWING**

PREMIER P/N: TSD-1347	REVISION: 09/17/99
DRAWN BY: TOM O'NEIL	REF: TOP224/TOP202
SCALE: NONE	SHEET: 1 OF 4

# APPLICATION NOTES

Premier Magnetic's TSD-1347 Switch Mode Transformer was designed for use with Power Integrations, Inc. PWR-TOP202YA1 three terminal off-line PWM switching regulator in the Flyback Buck-Boost circuit configuration. This conversion topology can provide isolated multiple outputs with efficiencies up to 90%. Premier's TSD-1347 transformer has been optimized to provide maximum power throughput.

The PWR-TOPXXX series from Power Integrations, Inc. are self contained 100KHz three terminal voltage controlled PWM switching regulators. This series contains all necessary functions for an off-line switched mode control DC power source. These switching regulators provide a very simple solution to off-line designs. The inductors and transformer used with the PWR-TOPXXX are critical to the performance of the circuit. They define the overall efficiency, output power and overall physical size.

Below is a universal input high precision 20 watt application circuit utilizing Power Integrations TOP223 switching regulator in the flyback buck-boost configuration. The component values listed are intended for reference purposes only. A properly sized heat sink for the TOP223 is required for efficient and reliable operation.

**FIGURE 3: TYPICAL APPLICATION CIRCUIT**

PREMIER MAGNETICS PART NUMBERS:  
(REQUEST DATA SHEETS BY PART#)

- L1 = PMCU-0330 33mHy EMI/RFI CMC
- T1 = TSD-1347 MAIN SWITCHING TRANSFORMER
- L2 = VTP-01001 10uHy, 1.0Amp INDUCTOR

ALUMINUM ELECTROLYTIC FILTER CAPACITOR RATINGS:

- 15V OUTPUT: C10 & C11 ≥25V, Ripple Rated ≥ 190mA @ 100KHz @ Max. Op. Temp.
- +24V OUTPUT: C12 & C13 ≥35V, Ripple Rated ≥ 600mA @ 100KHz @ Max. Op. Temp.
- +6.9V OUTPUT: C2 ≥10V, Ripple Rated ≥ 300mA @ 100KHz @ Max. Op. Temp.

PANASONIC HFG SERIES:

- C10 & C2 = 220uF, 25V = PANASONIC ECA1EFG221
- C11 & C3 = 100uF, 25V = PANASONIC ECA1EFG101
- C12 = 220uF, 35V = PANASONIC ECA1VFG221
- C13 = 100uF, 35V = PANASONIC ECA1VFG101

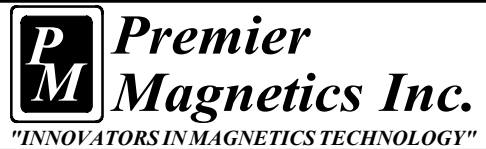
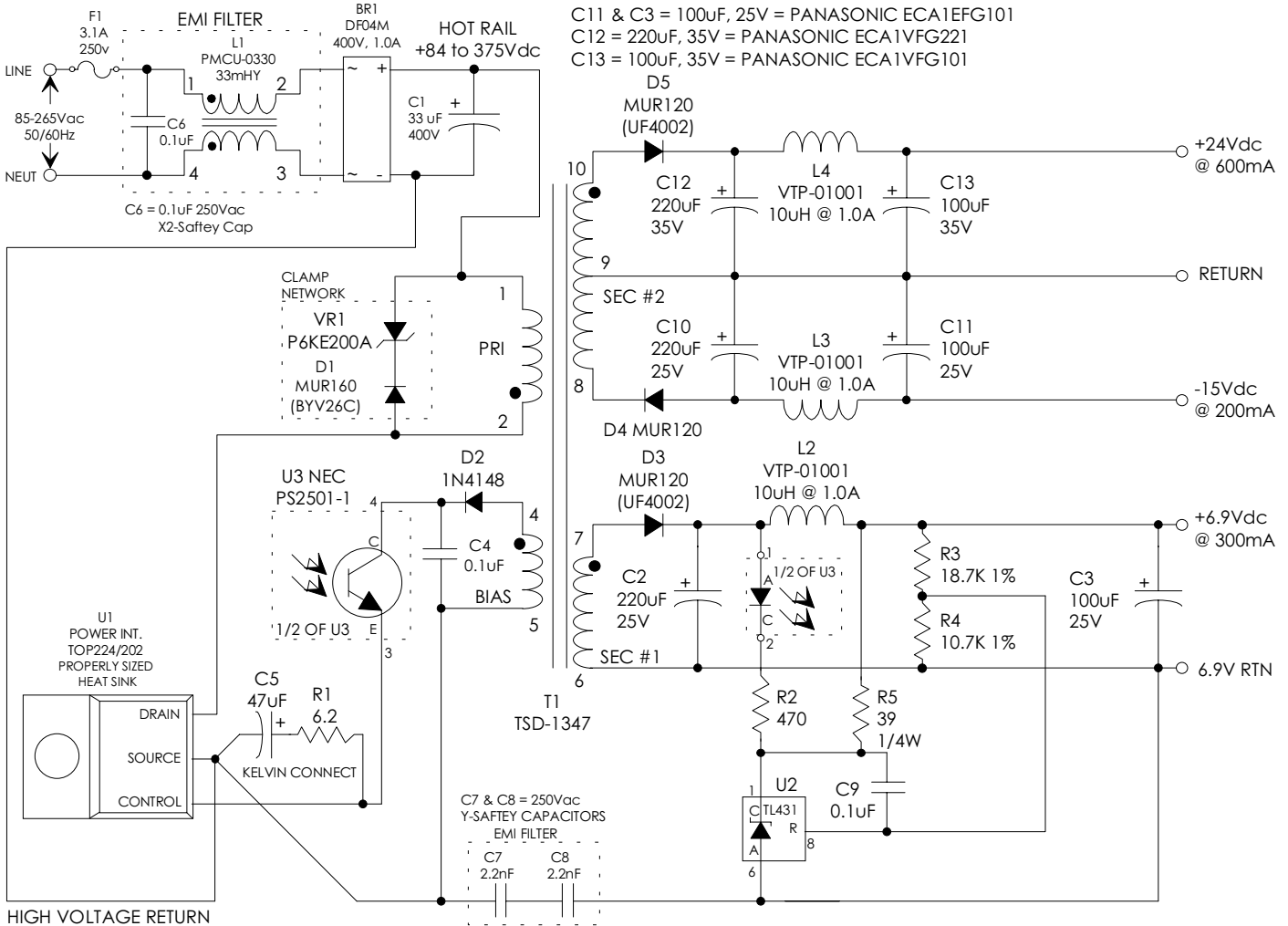

UNLESS OTHERWISE SPECIFIED  
DIMENSIONS ARE IN MM  
DIMENSIONAL TOLERANCES ARE:  
DECIMALS ANGLES  
.X ± .25 ±0° 30'  
.XX ± .15  
DO NOT SCALE DRAWING

FLYBACK TRANSFORMER CONTROL DRAWING	
PREMIER P/N: TSD-1347	REVISION: 09/17/99
DRAWN BY: TOM O'NEIL	REF: TOP224/TOP202
SCALE: NONE	SHEET: 2 OF 4