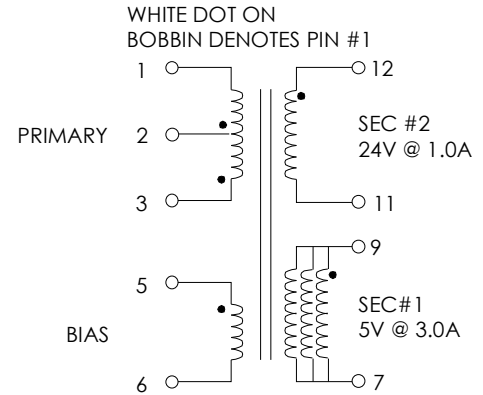

TABLE 1: ELECTRICAL SPECIFICATIONS AT 25 °C
 SWITCHING TRANSFORMER DESIGNED FOR USE WITH POWER INTEGRATIONS
 PWR-TOP204YA1. REFER TO APPLICATION CIRCUITS OF FIGURE 3.

PARAMETER	SPEC LIMITS			UNITS
	MIN.	TYP.	MAX.	
PRIMARY INDUCTANCE (3-1) VOLTAGE = 0.250Vrms FREQUENCY = 100 KHZ	810	900	990	μHY
TURN RATIO'S: SEC#1 (9-7) : PRIMARY (3-1) SEC#2 (12-11) : PRIMARY (3-1) BIAS (5-6) : PRIMARY (3-1)	-----	1:20.0 1: 4.44 1: 10	-----	± 4% ± 4% ± 4%
PRI LEAKAGE IND. (SEC'S SHORTED) FREQUENCY = 100 KHZ @ .250Vrms	-----	-----	45	μHY
HIPOT: PRIMARY TO SECONDARY BIAS TO SECONDARY SECONDARY TO SECONDARY	1500 1500 1500	----- ----- -----	----- ----- -----	Vrms Vrms Vrms
FIGURE 3 CIRCUIT PARAMETERS: (1) AC LINE VOLTAGE 47/400 Hz SEC #1 REGULATED OUTPUT VOLTS OUTPUT CURRENT CONTINUOUS OUTPUT CURRENT PEAK SEC #2 AUXILIARY OUTPUT VOLTAGE OUTPUT CURRENT CONTINUOUS OUTPUT CURRENT PEAK	85 ----- 0.100 ----- ----- 0.100 -----	----- 5.0 ----- 24.0 ----- ----- -----	265 ----- 3.00 3.30 ----- 1.0 1.20	Vac Vdc Amps Amps Vdc Amps Amps

(1) REFER TO APPLICATION CIRCUIT OF FIGURE 3.

FIGURE 1: SCHEMATIC DIAGRAM



NOTE1: REINFORCED INSULATION SYSTEM, UL1950, IEC950, CSA-950:

- A) ALL MATERIALS MEET "UL", "CSA" & "IEC" REQUIREMENTS
- B) DESIGNED TO MEET ≥6.2mm CREEPAGE REQUIREMENTS.
- C) VARNISH FINISHED ASSEMBLY.
- D) UL1950 & CSA-950 CERTIFIED: FILE #E162344.
- E) UL CLASS (B) 130 INSULATION SYSTEM PM130-R1, PM130-H1, PM130-H1A (UL FILE #E177139) OR ANY UL AUTHORIZED CLASS (B) INSULATION SYSTEM.



FIGURE 2: PHYSICAL DIMENSIONS mm (INCHES)

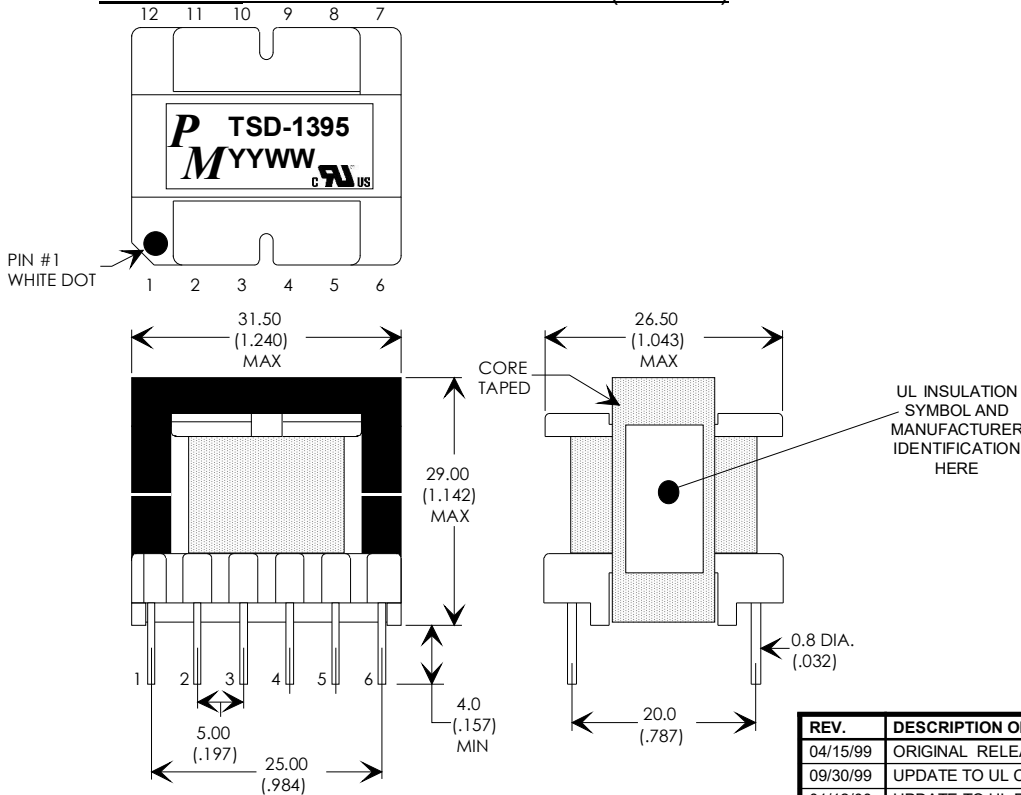

RoHS

REV.	DESCRIPTION OF CHANGES	BY
04/15/99	ORIGINAL RELEASE	PP
09/30/99	UPDATE TO UL CLASS (B) INSULATION SYSTEM	MD
01/12/00	UPDATE TO UL RECOGNIZED FILE #E162344	MD
10/16/01	CORRECTED SCHEMATIC PIN #	LL



UNLESS OTHERWISE SPECIFIED
 DIMENSIONS ARE IN MM
 DIMENSIONAL TOLERANCES ARE:
 DECIMALS ANGLES
 .X ± .25 ±0° 30'
 .XX ± .15
 DO NOT SCALE DRAWING

TRANSFORMER CONTROL DRAWING

PREMIER P/N: TSD-1395	REVISION: 10/16/01
DRAWN BY: PETER PHAM	REF: PWR-TOP224Y
SCALE: NONE	SHEET: 1 OF 2

APPLICATION NOTES

Premier Magnetics' TSD-1395 Switch Mode Transformer was designed for use with Power Integrations, Inc. PWR-TOP204YA1 three terminal off-line PWM switching regulator in the Flyback Buck-Boost circuit configuration. This conversion topology can provide isolated multiple outputs with efficiencies up to 90%. Premier's TSD-1395 transformer has been optimized to provide maximum power throughput.

The TOPSwitch-II series from Power Integrations, Inc. are self contained 100KHz three terminal voltage controlled PWM switching regulators. This series contains all necessary functions for an off-line switched mode control DC power source. These switching regulators provide a very simple solution to off-line designs. The inductors and transformer used with the TOPXXX are critical to the performance of the circuit. They define the overall efficiency, output power and overall physical size.

Below is a universal input high precision 40 wattS application circuit utilizing Power Integrations TOP204 switching regulator in the flyback buck-boost configuration. The component values listed are intended for reference purposes only.

FIGURE 3: TYPICAL APPLICATION CIRCUIT

PREMIER MAGNETICS PART NUMBERS:
(REQUEST DATA SHEETS BY PART#)

- L1 = PMCE-0330 33mHy EMI/RFI CMC
- T1 = TSD-1395 MAIN SWITCHING TRANSFORMER
- L2 = VTP-01002 10uHy, 2.0Amp INDUCTOR
- L3 = VTP-01001 10uHy, 1.0Amp INDUCTOR
- L4 = VTP-25001 250uHy, 1.0Amp INDUCTOR

ALUMINUM ELECTROLYTIC FILTER CAPACITOR RATINGS:

+24V OUTPUT:

- C10 $\geq 50V$ & Ripple Rated $\geq 1200mA$ @ 100KHz @ Max. Op. Temp.
- PANASONIC FU SERIES: LOW IMPEDANCE RADIAL SERIES
- C10 = 270uF, 50V = PANASONIC EEUFA1H271

+5V OUTPUT:

- C3 $\geq 16V$, C2 $\geq 16V$ & Ripple Rated $\geq 3330mA$ @ 100KHz @ Max. Op. Temp.
- PANASONIC FU SERIES: LOW IMPEDANCE RADIAL SERIES
- C2 = 3300uF, 25V = PANASONIC EEUFA1E825.0
- C1 = 270uF, 16V = PANASONIC EEUFA1C271

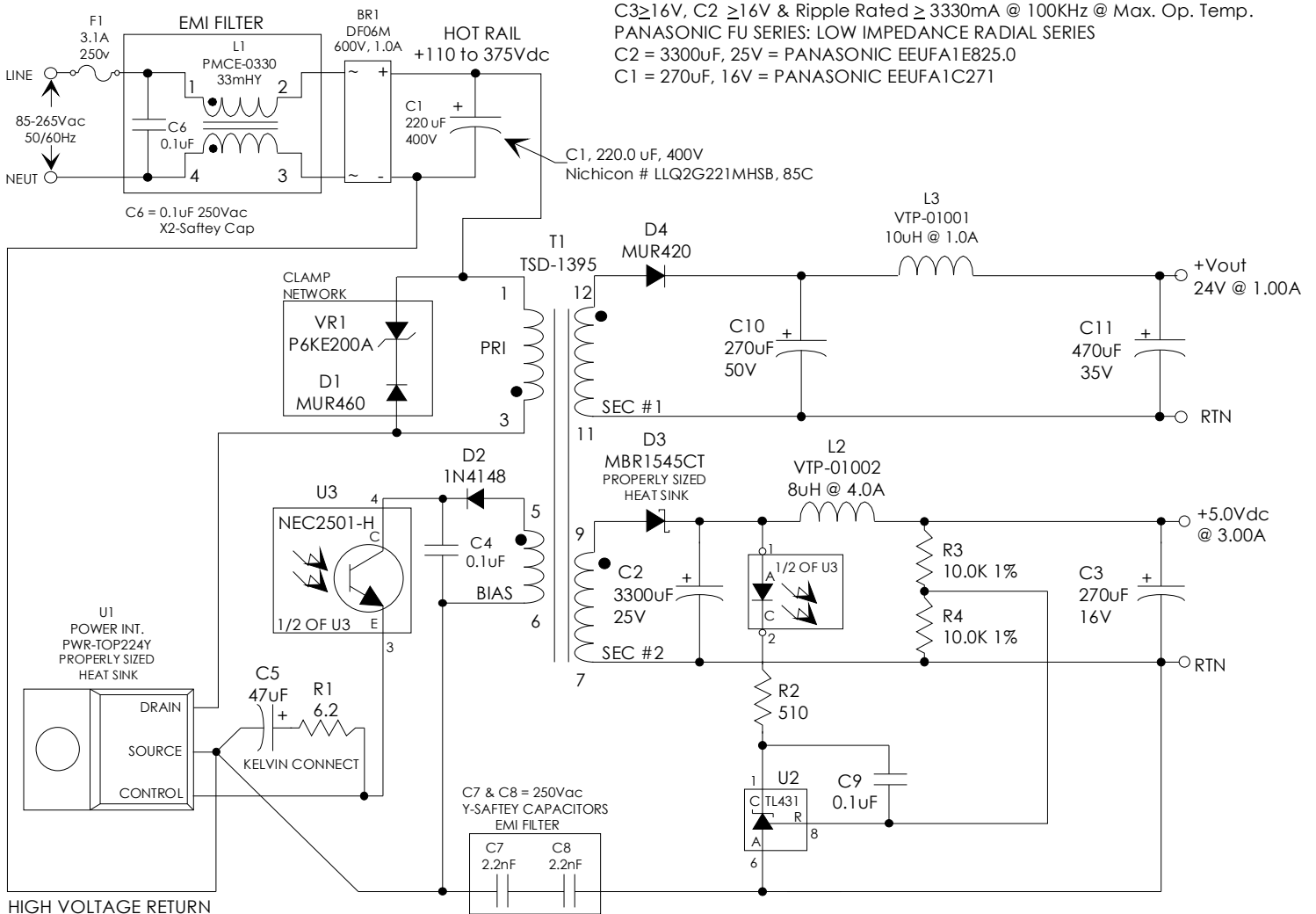

UNLESS OTHERWISE SPECIFIED
DIMENSIONS ARE IN MM
DIMENSIONAL TOLERANCES ARE:
DECIMALS ANGLES
.X $\pm .25$ $\pm 0^\circ 30'$
XX $\pm .15$
DO NOT SCALE DRAWING

TRANSFORMER CONTROL DRAWING	
PREMIER P/N: TSD-1395	REVISION: 10/16/01
DRAWN BY: PETER PHAM	REF: PWR-TOP224Y
SCALE: NONE	SHEET: 2 OF 2