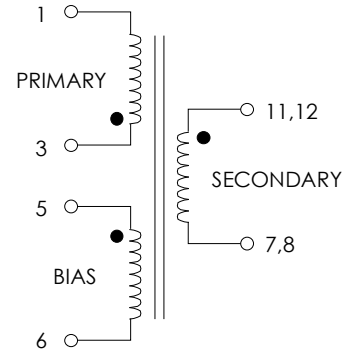

TABLE 1: ELECTRICAL SPECIFICATIONS AT 25 °C

PARAMETER	SPEC LIMITS			UNITS
	MIN.	TYP.	MAX.	
INDUCTANCE (3-1) VOLTAGE = .100 Vrms FREQUENCY = 100 KHz	332	368	405	μHY
TURN RATIO SEC (11,12 - 7,8) : PRI (3-1) BIAS (5-6) : PRI (3-1)	-----	1 : 4.4 1 : 7.33	-----	2% 2%
HIPOT: WINDING TO CORE	3000	-----	-----	Vrms

FIGURE 1: SCHEMATIC DIAGRAM



SECONDARY:
TIE PIN #7 TO #8 AND PIN #11 TO #12
ON PCB FOR MAXIMUM POWER

FIGURE 2: PHYSICAL DIMENSIONS mm (inches)

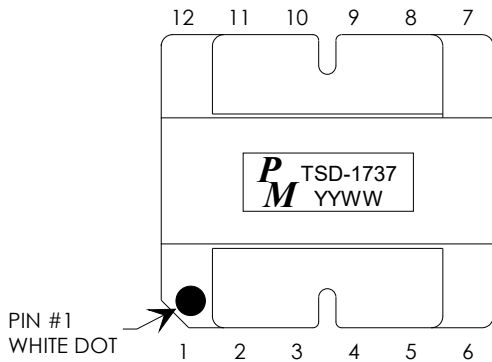

NOTE 1: MINIMUM INSULATION SYSTEM:

- A) ALL MATERIALS MEET "UL", "CSA" & "IEC" REQUIREMENTS
- B) ALL MATERIAL RATED 130 °C OR BETTER.
- C) TRIPLE TEX-E WIRE ON SECONDARY.
- D) VARNISH FINISHED ASSEMBLY.

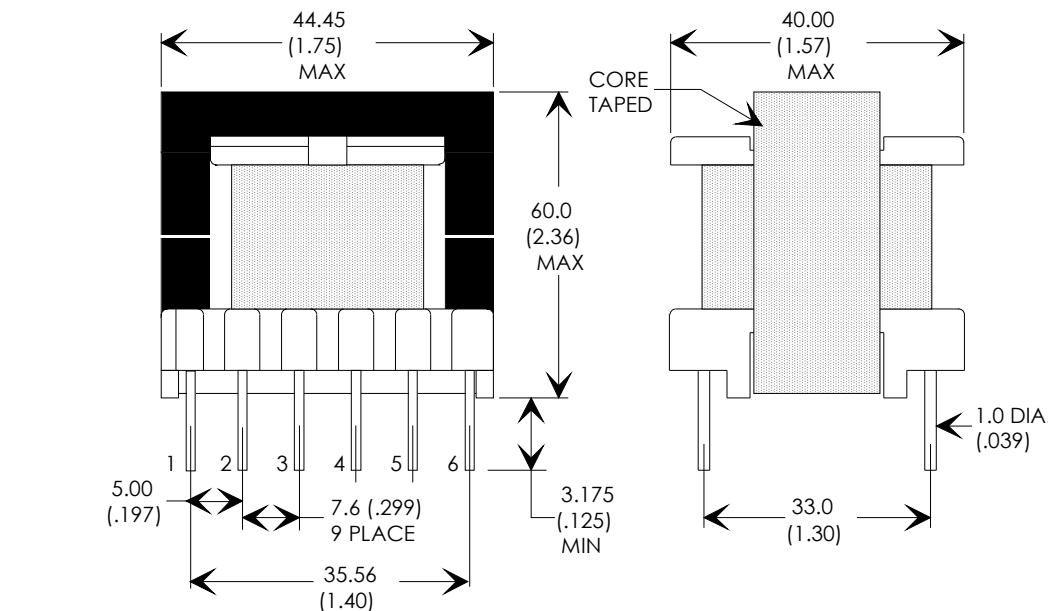

REV.	DESCRIPTION OF CHANGES	BY
01/29/02	ORIGINAL RELEASE	PP
03/06/02	CORRECTED PIN DIA. DIMENSION TO 0.039" WAS 0.032	LL
06/22/07	CORRECT START & FINISH ON SEC WDG INSTRUCTION	PP

RoHS



UNLESS OTHERWISE SPECIFIED
DIMENSIONS ARE IN INCHES
DIMENSIONAL TOLERANCES ARE:
DECIMALS ANGLES
.XX ± .02 ± 5°
.XXX ± .001
DO NOT SCALE DRAWING

TRANSFORMER CONTROL DRAWING

PREMIER P/N: TSD-1737	REVISION: 06/22/07
ENGR: PETER PHAM	REF: TOP247
SCALE: NONE	SHEET: 1 OF 3