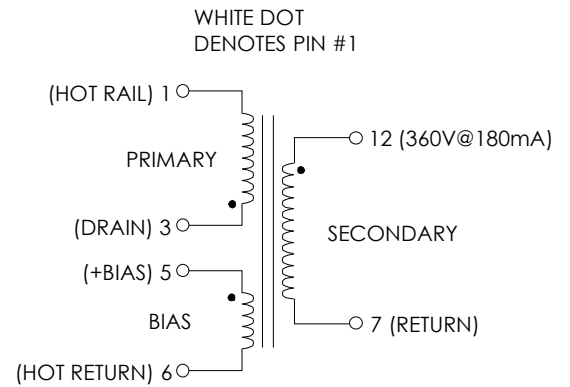

**TABLE 1: ELECTRICAL SPECIFICATIONS AT 25 °C**

PARAMETER	SPEC LIMITS			UNITS
	MIN.	TYP.	MAX.	
PRIMARY INDUCTANCE (3-1) VOLTAGE = 0.250Vrms FREQUENCY = 100 KHZ	425	470	515	μHY
TURN RATIO'S: SEC (12-7) : PRIMARY (3-1) BIAS (5-6) : PRIMARY (3-1)	-----	3.6 : 1 1 : 6.25	-----	± 4% ± 4%
PRI LEAKAGE IND. (SEC SHORTED) 0.250Vrms @ 100 KHZ	-----	-----	25	μHY
HIPOT: PRIMARY TO SECONDARIES BIAS TO SECONDARIES	3000 3000	----- -----	----- -----	Vrms Vrms

**FIGURE 1: SCHEMATIC DIAGRAM**



**NOTE1:**

- A) ALL MATERIALS MEET "UL", "CSA" & "IEC" REQUIREMENTS
- B) ALL MATERIAL RATED 130C OR BETTER.
- C) MARGIN TAPE TO MEET ≥6.4mm CREEPAGE REQUIREMENTS.
- D) VARNISH FINISHED ASSEMBLY.

**FIGURE 2: PHYSICAL DIMENSIONS mm (INCHES)**

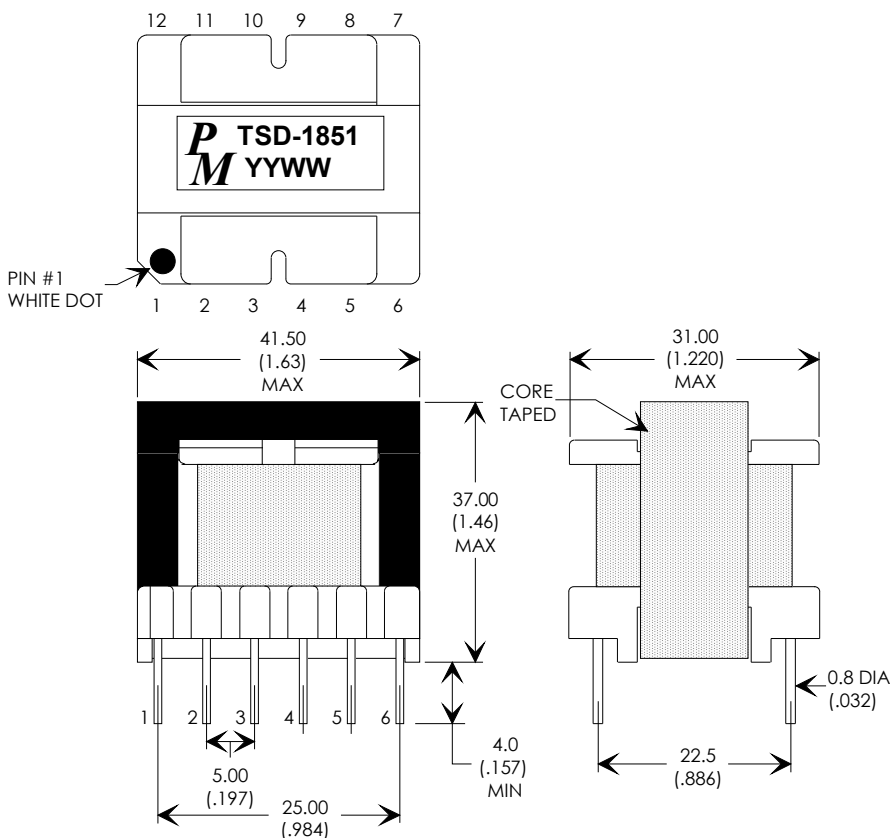

REV.	DESCRIPTION OF CHANGES	BY
05/08/03	UPDATE RELEASE, CHANGED LEAKAGE TO 25μH	PP



UNLESS OTHERWISE SPECIFIED  
DIMENSIONS ARE IN MM  
DIMENSIONAL TOLERANCES ARE:  
DECIMALS ANGLES  
.X ± .25 ±0° 30'  
.XX ± .15  
DO NOT SCALE DRAWING

**FLYBACK/FORWARD CONTROL DRAWING**

PREMIER P/N: TSD-1851	REVISION: 05/08/03
DRAWN BY: PETER PHAM	REF:
SCALE: NONE	SHEET: 1 OF 1